

Compression Ignition Engine Modifications for Straight Plant Oil Fueling in Remote Contexts: Modification Design and Short-run Testing

M. Basinger^{a,*}, T. Reding^b, C. Williams^c, K. S. Lackner^a, V. Modi^{c,**}

^a*Earth and Environmental Engineering, Columbia University, New York City, USA*

^b*Mechanical Engineering, Manhattan College, New York City, USA*

^c*Mechanical Engineering, Columbia University, New York City, USA*

Abstract

Though many plant oils have a similar energy density to fossil diesel fuel, several properties of plant oils are considerably different from those of diesel. Engine modifications can overcome some of these differences. An engine modification kit has been designed and tested for a slow speed, stationary, indirect-injection diesel engine - the Lister-type CS 6/1, common throughout the developing world. The kit allows waste vegetable oil fueling with similar performance to that of diesel fueling. The kit's simple yet robust design is targeted for use as a development mechanism, allowing remote farmers to use locally grown plant oils as a diesel substitute.

The modification kit includes a preheating system and the tuning of the injector pressure and timing to better atomize given the unique properties of straight plant oils. The design methodology for the modifications is detailed and a suite of performance test results are described including fuel consumption, efficiency, pre-combustion chamber pressure, and various emissions. The results of the study show how a combination of preheating the high pressure fuel line, advancing the injector timing and increasing the injector valve opening pressure allows this engine to efficiently utilize plant oils as a diesel fuel substitute, potentially aiding remote rural farmers with a lower cost, sustainable fuel source – enabling important agro-processing mechanization in parts of the world that needs it most.

Keywords: plant oils, straight vegetable oil, diesel engine, emissions, performance, CI engine

PACS: 88.20.ft

1. Introduction

The idea of fueling compression ignition engines on plant oil is as old as the diesel engine itself. In Rudolph Diesel's preface to his 1912 patent he wrote that the "use of vegetable oil for engine fuel may seem insignificant today but such oil may become in the course of time, as important as petroleum" [1]. It seems that over the decades since this patent, whenever petroleum prices suddenly increase a renewed interest in plant oil combustion occurs. This has resulted in a significant body of

*Corresponding author

**Principal corresponding author

Email address: mlb2133@columbia.edu (M. Basinger)

literature describing engine performance and resulting emissions of different oils in different engines. Some studies have investigated modifications to the engine that allow for straight fueling with plant oil, others blend plant oils with diesel, while others carry out a combination of these approaches.

More recently, biodiesel production (transesterification) has become a popular endeavor. Even so, biodiesel captures only a small fraction of the total diesel fuel market share – in 2007 the U.S.’s production of biodiesel was 1% the amount of fossil diesel sold [2]. Even if the entire world’s production of 115 billion liters of vegetable oil had been used for fuel in 2007, neglecting conversion losses as well as the debate on the use of food materials for fuel, this would only satisfy about 3/4 of the U.S. diesel fuel demand [3].

However, some niche contexts do offer immediate opportunity. The technology development and experimental results discussed in this paper are focused on the application of straight plant oils in diesel engines in the developing country context. Many developing countries lack adequate energy infrastructure. Modern fuels and generation systems are often inaccessible due to complex issues of financing, transportation, education/training, etc. The United Nations Development Programme (UNDP) reported that worldwide in 2005, nearly 2.4 billion people used traditional biomass fuels for cooking and nearly 1.6 billion people did not have access to electricity [4]. Mechanical power for agriculture processing from small, stationary diesel engines is a core development mechanism for rural populations. However, the cost and availability of fuel in these remote locations can prohibit the use of this important energy resource.

The use of locally grown, non-edible, plant oils to fuel slow-speed diesel engines has potential to provide a low cost, sustainable solution. The ruggedness of engines like the Listeroid CS and its widespread availability lend itself to this application.

2. SVO Fueling Methodology

The combustion of plant oils in diesel engines is influenced by qualities of both the oil and the engine. Different studies have found different results and reached different conclusions depending on the type of oil and engine that were used. Few experimental studies reach across engine type and oil type to elucidate these trends [5, 6]. What follows is a brief review of the impact of the oil and the impact of the engine on plant oil combustion.

2.1. *The Impact of the Oil*

The processing of plant oils is complex. An entire industry surrounds the procedures and practices involved in taking oil-crops from the field to the food-stand, or fuel tank. Extremely large, multivolume works, such as Baily’s Industrial Oil & Fats Products, detail every aspect of this industry [7]. Some vegetable oil combustion studies have found that the degree or type of processing of the oil has little impact on engine performance or emissions while others recommend at least degumming in order to remove phosphatides [5, 6]. A detailed treatment of all the combustion implications from the different degrees of processing of plant oils is beyond the scope of this paper.

The term straight vegetable oil (SVO) will hence forth be used to simply differentiate plant oil from biodiesel. Specific properties of different SVOs are discussed, in order to highlight broad differences from one type of plant oil to the next as they generally relate to combustion.

The two primary motivations behind transesterification are to remove the glycerin “head” of the vegetable oil and to reduce the viscosity. The glycerin in SVOs has been shown to lead to engine deposits in endurance testing [8, 9]. High viscosity can impede flow in the fuel lines and filter but is of most concern with regard to its impact on atomization. For this reason the high viscosity of SVO

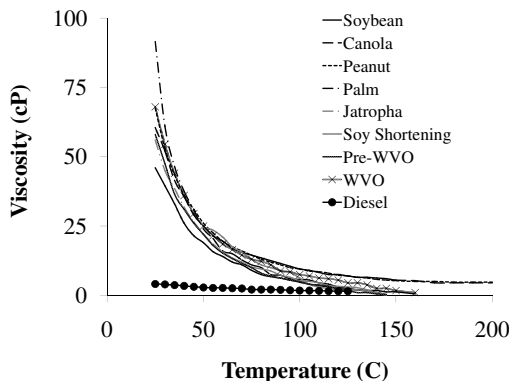

Figure 1: Viscosity vs. Temperature of Several Plant Oils and Diesel

has been the property of greatest emphasis in most SVO combustion research. Improvements to viscosity can be obtained through preheating. As shown in Figure 1, SVO viscosity is exponentially reduced as temperature increases.

A Brookfield viscometer, model LVT-D, and a hotplate were used to measure the dynamic viscosity of the eight vegetable oils and number 2 diesel fuel. Each sample was heated in five degree increments; the viscosity measurements are shown in Figure 1. The soy, canola, and peanut samples were cooking oils obtained from a commercial food market. The waste vegetable oil (WVO) is used cooking oil from a local cafeteria; it is the same sample used throughout this paper. The pre-WVO, from which the WVO is derived, is a mix of soy and canola cooking oil. Full parameter, chemical, and lipid analysis of the WVO is provided in the appendix in Tables A.2 through A.4.

A regression utilizing equation (1) can be fit to the viscosity versus temperature curves from Figure 1, where μ is the viscosity in centi-Poise and T is the temperature in Celsius. Coefficients A , B , and C for each oil are shown in Table 1. The temperature range over which the viscosity was measured is also provided.

$$\mu = A + Be^{CT} \quad (1)$$

Though the high viscosity of unheated SVOs is a major issue for combustion in modern diesel engines, there are several other physical and fuel properties that also warrant attention. Table A.2 in the appendix lists some of these properties for a few SVOs.

The oil yield per land area per year is important when considering scaling issues surrounding the use of SVOs as fuel. Soil, climate condition, agricultural inputs (fertilizer, etc.), plant variety, and other factors all impact yield. Due to the complexity of these factors and their interactions, Table A.2 provides an oil yield information as a range. Other important SVO properties, such as energy density, can be compared more succinctly. For example, the energy density, or calorific value, of SVOs is generally about 10 percent less than number 2 diesel, though will vary from SVO to SVO. This lower energy density results in higher fuel consumption compared to fossil diesel.

The cetane number (CN) also has important combustion implications. The CN is a measure of

Table 1: Viscosity-Temperature Coefficients

	A	B	C	Correlation Coefficient	Temperature Range (C)
Soybean	1.110	109.6	-0.036	0.999	25 to 160
Canola	5.590	141.9	-0.038	0.998	25 to 200
Peanut	5.768	165.9	-0.041	0.998	25 to 200
Palm	3.265	327.2	-0.055	0.993	25 to 145
Jatropha	1.607	134.1	-0.037	0.999	25 to 145
Soy Shortening	-3.638	89.30	-0.022	0.996	50 to 145
Pre-WVO	1.040	146.7	-0.039	0.998	25 to 145
WVO	3.486	171.1	-0.040	0.997	25 to 160
Diesel	1.015	5.058	-0.019	0.996	25 to 125

a fuel's ignition delay quality; a higher CN corresponds to a shorter ignition delay. Long ignition delay is undesirable due to the consequences of engine knock. A CN between 40 and 60 is preferable [10]. Some negative aspects of an SVO's ignition quality can be lessened or avoided through tuning the engine's injection timing for the particular fuel.

Vegetable oils are hydrocarbons, though much heavier, and less volatile than number two diesel [11]. The chemical composition of SVOs is important when considering combustion implications. Table A.3 in the appendix shows the C:H:O:S:N ratio for several SVOs. The occurrence of oxygen in the SVO molecule is advantageous, enhancing mixing-limited combustion and even reducing particulate emissions, though potentially increasing NOx [12, 13]. The existence of nitrogen and oxygen in SVOs has valuable lubricity benefits [14].

The ratio of an SVO's C:H:O:S:N is meaningful, but the bond configuration of these elements, the lipid profile, is also important to consider. Different fatty acid chains occur in significantly different amounts for different oils. This lipid profile has implications for combustion. Many investigations have shown high amounts of unsaturated fatty acid chains, especially linolenic and linoleic chains, increase engine wear as a result of the polymerizing quality of the heavy polyunsaturated lipids [15, 9, 6]. There is a trade-off however. The degree of saturation of an oil impacts cold flow properties. Soybean oil may have more polymerizing qualities compared to palm oil, but at low temperatures, such as those often found in temperate climates during winter months, the cloud point and pour point of palm oil can prohibit its use as a non-blended, non-preheated fuel. The lipid profile has also been shown to directly influence ignition delay and in turn NOx and particulate emissions [16].

Ryan and Bagby found that it is not only an SVO's physical properties (viscosity), but its chemistry can also impact atomization characteristics. Polyunsaturated lipids such as linolenic and linoleic chains were most affected during the injection process, resulting in unexpected injector spray characteristics [17].

Structural indices such as the saponification value (SV) and iodine value (IV) are used to quickly describe constituent lipid qualities. The SV is a measure of the average molecular weight, or chain length, of the fatty acids present in an oil. The IV describes the unsaturated quality, the amount of double bonds, of an oil. An IV is assigned to an SVO based on the amount of iodine that can be absorbed by the double bonds. The IV neglects the differentiation between polyunsaturated acids and monounsaturated acids. Knothe describes other, less common indices that can be used to overcome the limitations of the IV [18]. For the time being however, the widespread use of the

IV means that it is often readily available across studies, making it a useful index. Table A.4 in the appendix provides the lipid profiles and iodine values for several SVOs.

2.2. *The Impact of the Engine*

Several SVO engine study reviews highlight the role of the engine type and configuration in influencing combustion; depending on the engine and modification used in a study, results can differ significantly [8, 9, 10, 11, 19, 20, 21]. Engine speed and loading has been found to be important. Vojtisek-Lom, Blazek, et al. investigated rapeseed SVO fueling and found at higher engine loads CO levels improved while NOx worsened compared to diesel, while at low engine loads HC, CO, and PM worsened [22]. In addition to load, the design of specific components also impacts SVO combustion. Piston configuration and injector design are influential, but most often an emphasis is placed on the type of injection system, direct or indirect.

Modern diesel engines tend to have direct injection (DI) systems due to the improved efficiency and emissions it can offer. Older designs, sometimes relics from days with less stringent fuel quality standards, utilized indirect injection (IDI) systems because of its ability to robustly burn lower quality fuel. The general trend in SVO combustion studies seems to confirm this value of IDI systems. Hemerlein, Korte et al. showed that DI engines fueled on rapeseed SVO tended to have poorer emissions and were not suitable for direct fueling, while IDI engines with big cylinders were suitable [5].

Ryan, Dodge, et al. tested multiple SVOs in a DI and IDI engine and found increased nozzle coking and lubrication contamination compared to diesel in the DI engine but not in the IDI engine, though the specific energy consumption of the DI engine was generally better than the IDI engine [6]. However, Engler, Johnson, et al. found that though short run IDI engine tests were favorable for various degummed SVOs, longer 40 hour tests revealed rapid fouling of the lubrication oil [23].

Suda showed that in some DI engines unburned fuel impingement on the cylinder wall results in deposits, ring and cylinder wear, and lubrication oil contamination [24]. Suda also tested soybean SVO in an IDI with a pre-combustion chamber and designed a special heat plug to allow the engine to robustly burn the SVO.

Redesigning major engine components is often less desirable than more minor modifications. The most common minor engine modification is to preheat the SVO. Different studies have made different conclusions with regard to just how much to preheat. Bari, Yu, et al. found heating between 55 and 70 degrees Celsius was adequate for reducing filter clogging and improving engine performance and emissions characteristics [25, 26]. Pugazhivadivu and Jeyachandran found preheating to 135 degrees Celsius to be preferable [27]. Nwafor investigated the impact of preheating rapeseed SVO to 70 degrees Celsius and found at low speed and partial loading it was beneficial, but at higher speeds and loads it had less impact [28]. Analysis of properties of various SVOs has shown temperatures between 200-300°C to result in thermal decomposition, while higher temperatures approach the flash point [29]. Even lower temperatures have been argued to result in overheating the SVO. Bari, Lim, et al. noted that at 100 degrees Celsius vapor bubbles occurred in the fuel line, resulting in non-ideal combustion [30]. Suda found that at 90 degrees Celsius oxidation can occur, resulting in gum formation [24].

Another common minor modification is to increase the injector valve opening pressure (IVOP). Increasing a diesel engine's IVOP has been shown to decrease fuel spray droplet diameter, and increase velocity and penetration distance resulting in a host of engine performance and emissions improvements [31, 32, 33, 34, 35]. Initial average fuel spray droplet diameter has been shown to be inversely related to its velocity squared [36]. This means that as velocity increases (from increased

IVOP), droplet size rapidly decreases. Droplet evaporation can be described by the D2 law, which relates evaporation rate to the droplet diameter squared [37]. Decreasing the droplet diameter can then significantly increase evaporation rates, thus enhancing combustion. This dual exponential relationship between droplet evaporation time and diameter, and between diameter and velocity means that even relatively small increases to the IVOP can have significant combustion advantages.

It has already been discussed how SVOs are more viscous and heavier than number 2 diesel fuel; this has been shown to result in considerably larger droplet diameters and lower injection velocities, as described by lower Weber numbers [38, 39]. For these reasons SVOs in particular can benefit from increased IVOP. Enoki, Hayashi, et al. noted an improvement in brake thermal efficiency, ignition, and combustion stability with increased IVOP in an IDI engine fueled on various SVOs [33]. Puhan, Jegan, et al. also found improved engine performance and emissions from increased IVOP in a DI engine fueled on linseed methyl esters [40].

There is a point where increasing the IVOP becomes counterproductive. This is due to increased spray penetration resulting in wall impingement [33]. For this reason it can be valuable to “tune” a particular engine’s IVOP for the specific SVO.

Injection timing is another minor modification that has been employed to help the performance and emissions of SVO fueled diesel engines. Haldar, Gosh, et al. observed enhanced engine performance with advanced timing, they attributed this to the lower cetane number of SVOs [41]. Bari, Yu, et al. investigated timing effects on a WVO in a DI engine. They found advanced timing improved efficiency and reduced CO emissions, though it elevated NOx emissions [26]. Nwafor, Rice, et al. also found benefits from advancing the timing of a rapeseed SVO fueled IDI engine. The engine ran smoother and both CO and CO2 emissions improved [42]. This was attributed to the longer ignition delay and slower burning rates of plant oils. However, delay period was also found to be influenced by engine load, speed and temperature. Similar to IVOP findings, advancing the timing too far can have negative consequences, resulting in erratic engine behavior [42].

3. Experimental Setup

As shown in Figure 2 a slow speed stationary engine common to remote rural developing country settings was fueled with waste vegetable oil (WVO). A modification kit was developed and tested.

3.1. System Overview

Listeroid engines are used throughout developing countries for agro-processing. These engines are typically 6 to 16 horsepower, vertical, stationary, water cooled with large flywheels. These engines weigh more than 300 kilograms. For this study a Listeroid CS (cold start) 6/1, 650 RPM, 4-stroke, 114.3 mm x 139.7 mm bore/stroke, water cooled, IDI diesel engine was used to drive an ST-5 5kW generator head which was loaded by a bank of light bulbs. The ST-5 was chosen to provide the load to the engine because it is a generator commonly paired with Listeroids throughout the developing world. Engine load was measured from a power meter which logged volts, amps, frequency, and power factor. Engine speed was measured with a Hall Effect sensor and a magnet on the flywheel.

The engine coolant system was comprised of a 55 gallon drum filled with water, circulating via a passive thermal siphon cycle. Two type J thermocouples were used to measure water coolant level entering and exiting the engine. A thermostat was used in the engine coolant exit to speed up the rate at which the engine reached steady state. Steady state was defined as the point where the

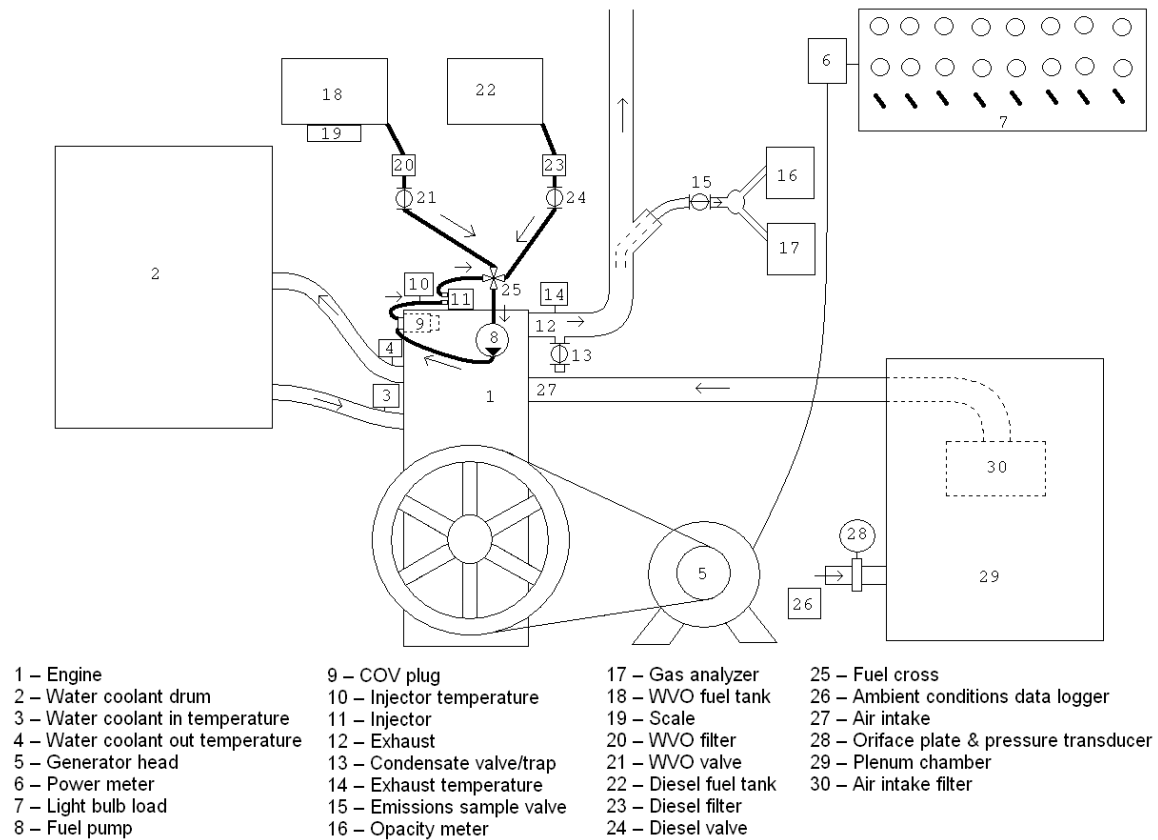

Figure 2: Experimental Setup

water coolant temperature leaving the engine was stable and consistent; this occurred after about 90 degrees Celsius.

The air intake flow rate was measured via an orifice plate & pressure transducer. A plenum chamber was utilized to attenuate the air flow pulses, sized per SAE standards [43]. Ambient temperature, pressure, and relative humidity were measured near the plenum chamber entrance.

A dual fuel tank approach was utilized – the engine was started on diesel to allow the preheater to come up to temperature and shutdown on diesel so that the high pressure fuel lines and pump were purged of the WVO. Each fuel tank had its own filter. The WVO was pre-filtered to 1-micron before being added to the fuel tank.

The WVO’s “on-engine” filter (post fuel tank) was 80 mesh, to reduce a pressure drop that could result in starving the engine of fuel. To minimize mixing between the two fuels, the injector’s fuel return line was not routed back to either fuel tank, but instead directly to the juncture of the two fuel lines (SVO and diesel) situated just before the fuel pump. This point is labeled as the “fuel cross” in Figure 2.

The opacity of the exhaust was measured using an AutoLogic model # 310-0332 opacity meter to take readings at 16 Hz that were then averaged across a 10 minute sampling window. To measure gaseous emissions, an Enerac 700 integrated emissions system was used to measure O₂, CO, CO₂, unburned hydrocarbons (UHCs), NO, NO₂, and SO₂. Data was collected once per second as parts per million (ppm) or vol%, depending on the concentration. Readings were averaged across a ten minute steady state window (steady state referring to both engine stabilization and the stabilization of the gas analyzer measurements).

4. Preheater Design

In order to lower the viscosity of the WVO to a level comparable to diesel, a preheater was designed to take advantage of the Listeroid CS’s special characteristics. The original design of the engine included a “Change Over Valve” (COV) for adjusting the compression ratio for easier start-up in cold climates. This original design is shown in Figure 3. As this engine is now manufactured and used in primarily warm climates, the COV has been replaced by a COV plug. This COV plug’s direct access to a large amount of waste heat through the cooling jacket, nearby location to the injector, and easy removal for use in a modification kit, made it an appealing candidate for use as a preheater.

Various methods of using the COV plug as a preheater were explored. A priority was placed on a design that could be easily manufactured in a basic machine shop making it appropriate for deployment and servicing in a developing country context. The final design consisted of machining a “V-shaped” passageway to route the fuel through as shown in Figure 4. The inlet and outlet were tapped to allow compression fittings to be attached so that the high pressure line could be connected as shown in Figure 2.

More complex geometries could have been utilized to further aid heat transfer, but the “V-shape” channel was chosen as it was believed to possess an optimal ease and cost of local manufacturability for the target context. The passageway diameter was chosen to be 0.635 cm (0.25 in). It was assumed that any larger diameter would potentially adversely affect the injection timing or risked overexerting the fuel pump (due to the increased volume of fuel and its compressibility under high pressure). The length of the passageway was chosen to be 11.43 cm (4.5 in); a longer length would have been within 1.3 cm (0.5 in) of the pre-combustion chamber leaving a thickness of material that might be susceptible to failure. A simplified heat transfer model aided the design of the geometry,

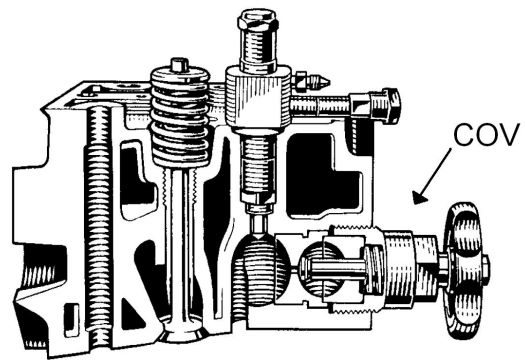

Figure 3: Original Lister CS Head and COV[44]

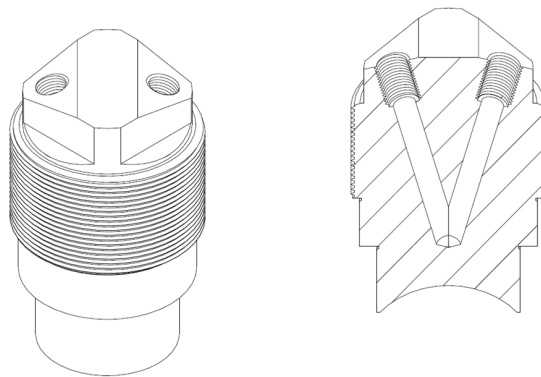

Figure 4: COV Plug Modification

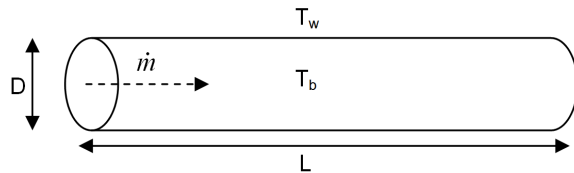

Figure 5: Heat Transfer Model

showing that the fuel would not be over or under heated. The performance was then confirmed experimentally.

Before building the preheater, to estimate the performance of the “V-shaped” passageway was modeled as a 1-D heat transfer problem. The modeled passageway was a straight tube with diameter D and length L with the same values as the “V-shaped” diameter and length. The mass flow rate of the fuel flow through the passage way was designated \dot{m} , with a bulk temperature T_b , and a wall temperature T_w , as shown in Figure 5. This simplification allowed the utilization of well known empirical correlations for determining the heat transfer coefficients.

The bulk temperature of the fuel (T_b) was defined by equation (2):

$$T_b = \frac{T_f + T_i}{2} \quad (2)$$

Where T_i was the initial temperature of the fuel entering the passageway and T_f was the final temperature leaving the passageway. In a convection dominated system, the overall power utilized to raise the temperature of the fuel can be calculated by equation (3):

$$\dot{q} = \dot{m}c_p(T_f - T_i) = hA(T_w - T_b) \quad (3)$$

where c_p is the specific heat of the fuel and is a function of T_b . A is the surface area in the tube. h is the convection coefficient and is a function of the Nusselt number (Nu). For laminar, fully developed flow in a horizontal tube, an empirical relation has been developed and is expressed in equation (4) [45, 46]

$$Nu = \frac{hD}{k} = 0.61 (ReRa)^{1/5} \left[1 + \frac{1.8}{(ReRa)^{1/5}} \right] \quad (4)$$

Where Re and Ra were the Reynolds Number and Raleigh Number, respectively, and defined in equations (5) and (6).

$$Re = \frac{UD}{\nu} \quad (5)$$

$$Ra = \frac{g\beta(T_w - T_b)D^3}{\nu\alpha} \quad (6)$$

where U was the average velocity of the fuel, ν was the kinematic viscosity of the fuel, g was the gravitational acceleration, β was the volumetric thermal expansion coefficient of the fuel (assumed to be constant), and α was the thermal diffusivity of the fuel. ν and α were functions of T_b . For a given T_w and T_i , T_f can be iteratively solved for through utilizing equations (2) through (6). In

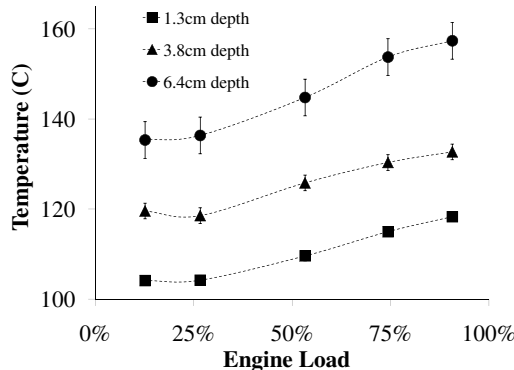

Figure 6: COV Temperature Profile

order to find appropriate values of T_w a thermal profile of the COV plug was measured through the following experimental setup.

Five thermocouples were installed into the COV plug in an “X” configuration, first at a depth of 1.3 cm (0.5 in) into the plug from the exterior of the engine, then 3.8 cm (1.5 in), and finally 6.4 cm (2.5 in). These depths extended across 80% of the total COV plug length. The five measured temperatures were averaged at each depth for each load tested and this thermal profile of the plug is shown in Figure 6. Error bars indicate standard deviation between the 5 thermocouples, averaged across the five loads at the specific depth.

For purposes of a simple theoretical calculation of T_f the wall temperature of the passageway (T_w) was assumed to be uniform across all depths, but vary depending on the load, so the average temperature across all depths was used as the T_w for each load.

To justify the use of equations (2) and (3) the role of convection relative to conduction needed to be determined so the Rayleigh Number (Ra) of the waste vegetable oil traveling through the passageway was calculated using the measured T_w . The Rayleigh number exceeded 50,000 for all engine loads (10%-90%), validating the assumption that convection dominated [45].

T_f was found through iteratively solving equations (2) through (6). This theoretical T_f was compared to the experimentally measured temperature at the injector utilizing the actual geometry. Figure 7 shows the agreement between the calculated theoretical and the experimentally measured.

The differences between the calculated and measured results are likely due to the following.

1. The simplifying assumption of laminar flow is inaccurate. The fuel pump pushes fuel through the preheater in pulses which likely enhance heat transfer.
2. The experimental measurement of the fuel temperature was not at the exit of the preheater (T_f), but instead approximately 15 cm (6 in) downstream at the inlet to the injector. Though this 15 cm (6 in) of fuel line was insulated, some temperature loss would have occurred, meaning the experimental values in Figure 7 are lower than the actual T_f .
3. The wall temperature of the passageway (T_w) was assumed to be uniform and only vary with load. But the measured COV plug thermal profile showed increasing temperature with

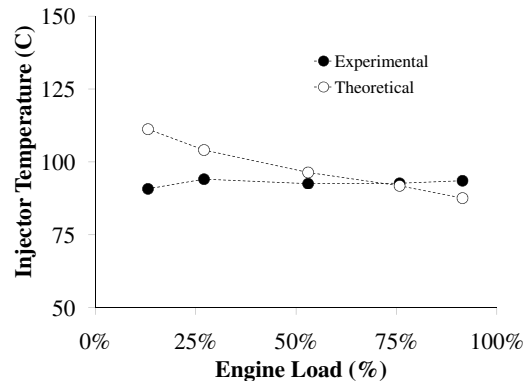

Figure 7: Injector Temperature Performance

increasing depth into the plug. These higher temperature ranges would have made the heat transfer more favorable than the simplified model represented.

Even with these limitations of the model, the design was verified and the performance of the preheater was found to increase the temperature of the WVO entering the injector to a satisfactory level (approximately 90 degrees Celsius), significantly reducing viscosity.

4.1. Pressure and Timing

As discussed above, the combustion characteristics of WVO are different from that of fossil diesel. A more complete burn can occur from increased injector valve opening pressure (IVOP) and advanced injector timing.

To increase the IVOP on the Listeroid CS engine, a cap on the top of the injector is removed, a lock nut loosened, and a screw tightened. Equally as simple, advancing the timing involves loosening a lock nut under fuel pump and raising an adjusting screw. Because of the minimal overhead with regard to tools and training required to make each of these modifications, both were determined to be appropriate additions for the modification kit's targeted context.

5. Results and Discussion

The performance of the modification kit described above (preheater, increased IVOP, advanced timing) was experimentally tested through multiple methods.

5.1. Injection Tuning

In order to tune the engine's timing and IVOP to optimal conditions for the WVO, three timing settings (20° BTDC, 25° BTDC, and 30° BTDC) and three IVOPs (9 MPa, 12 MPa, and 15 MPa) were tested. Higher IVOPs were tested previously but erratic performance precluded further exploration past 15 MPa. Each of these nine settings was tested three times each at 75% engine load (+/- 1%) and 650 RPM (+/- 1 RPM). For all of the 27 tests, the fuel was preheated via the COV plug design detailed above. The summary of the engine's performance across these tests

is detailed below. Error bars signify standard error across the three repetitions, for each of the 9 different settings. Figure 8 shows various engine performance parameters. All four parameters point toward an optimized tuning of the injector timing at 25° BTDC with an IVOP of 15 MPa.

The temperature of the middle of the exhaust stream was measured immediately off the engine head with a type-J thermocouple. The results are shown in Figure 8 (a). A clear difference in temperature occurs primarily from increasing the IVOP. As the timing advances the exhaust temperature is lowered to a point, and then increases again. The lowered temperature is likely indicative of more complete combustion, whereas the hotter temperatures are likely due to less complete combustion that continued late into the cycle [27]. These results follow the same trend as the findings from Bari et. al. where advanced timing of a DI engine fueled on WVO resulted in lower exhaust temperature, due to combustion occurring earlier, thus allowing the burnt gas more time to cool [26].

Figure 8 (b) shows the brake specific fuel consumption for the system (generator and electrical losses were not subtracted). With a trend nearly identical to the exhaust temperature, the best performance was found at the timing of 25° BTDC with an IVOP of 15 MPa. These results relate well to the findings of Nwafor et. al., where advanced timing of an IDI engine resulted in lower BSFC at low engine speeds [42].

Given WVO's measured higher heating value of 39.4 MJ/kg, the brake fuel conversion efficiency was calculated (the generator and electrical system was assumed 82.5% efficient). Figure 8 (c) shows how tuning the IVOP and timing can result in a gain of 2% efficiency. Such a gain is significant when considering the modest efficiency of the engine. This trend toward improved efficiency at advanced timing is similar to Halder's findings [41].

The equivalence ratio is the actual fuel to air ratio divided by the stoichiometric fuel to air ratio and is a direct indicator of the quality of combustion. Figure 8 (d) shows the equivalence ratio across the nine test points. In strong agreement with all other engine performance parameters, the equivalence ratio map reinforces the hypothesis that when fueling the Listeroid CS 6/1 on WVO, optimal tuning occurs at the timing of 25° BTDC with an IVOP of 15 MPa.

These engine performance benefits that were gained by advancing the timing and increasing the IVOP can likely be attributed to the specific atomization and ignition qualities of the WVO. As discussed earlier, plant oils have poorer atomization qualities due to their specific physical and chemical properties. The Cetane Number (CN) of the WVO used in the experiments, as shown in Table A.2, is low compared to fossil diesel, meaning that ignition is delayed. Advancing the injection timing then helps to overcome this high ignition delay. Similarly, increased injection valve opening pressure has been shown to reduce the droplet size, decreasing the burn time and leading to more complete combustion (as described above). This more complete combustion is also seen in the emissions.

The measured opacity values are reported in Figure 9. The results show that at the most advanced injector timing (30° BTDC), regardless of IVOP, opacity is worse than at stock timing (20° BTDC). However, in agreement with the engine performance data from Figure 8, increasing the IVOP improves the opacity. This vividly shows an engine tuning "envelope" effect - advanced timing and increased IVOP improves combustion, but only to a point, where it then begins to degrade combustion. When injection is advanced too far cylinder conditions are not optimal for good atomization. Temperatures and pressures rise rapidly close to TDC. These conditions are important for appropriate mixing and vaporization which lead to good combustion. Advancing the injection too much introduces the fuel spray into the cylinder before these conditions are available.

The measured gaseous emissions are reported in Figure 10. For both the carbon monoxide and

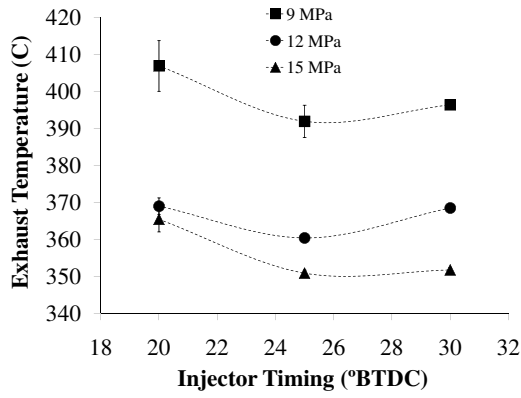

(a)

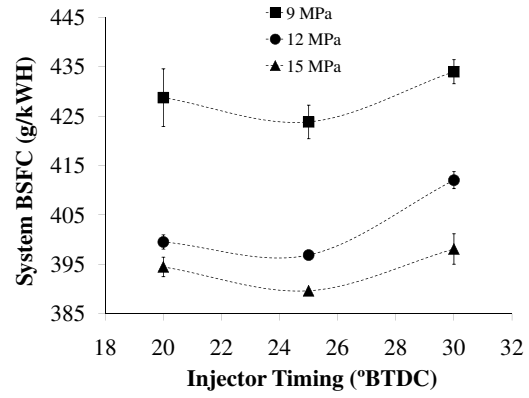

(b)

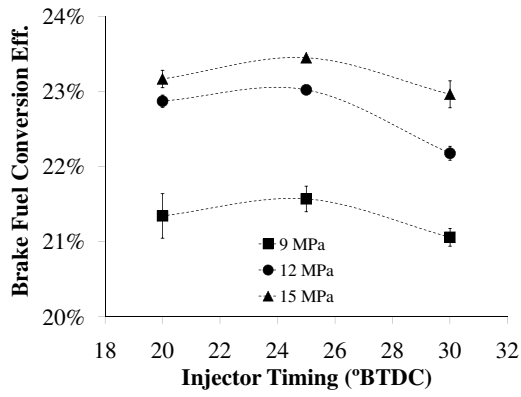

(c)

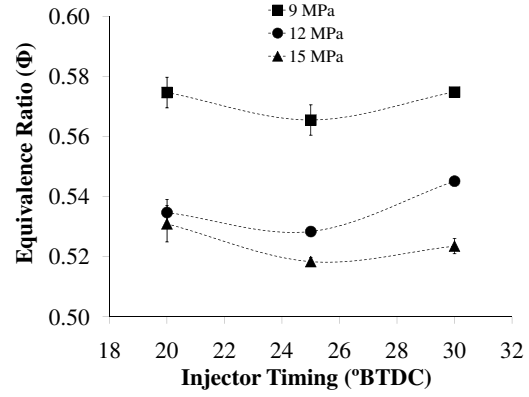

(d)

Figure 8: IVOP & Timing Performance Map

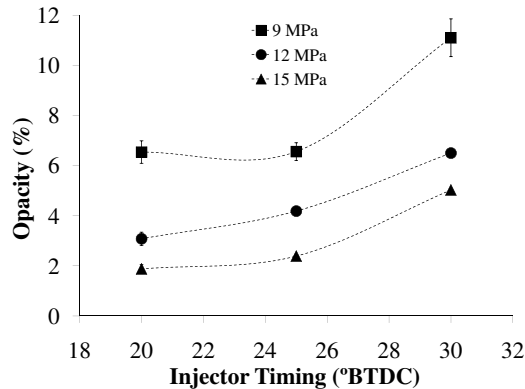

Figure 9: IVOP & Timing Exhaust Opacity Map

the oxides of nitrogen, the 12 MPa IVOP results so closely resembled the 15 MPa IVOP results that they have not been shown in Figure 10 (a) and (b). Instead, the low and high IVOP setting are shown to illustrate the envelope.

At the lower IVOP more CO is generated, but less NO_x. (NO_x is reported as the sum of measured NO + NO₂.) This common CO - NO_x trade off (also described as a PM-NO_x trade off) points again to the quality of the combustion. As the IVOP is increased, atomization improves. In diesel engine combustion, carbon monoxide production tends to be low under fuel lean conditions (equivalence ratio less than 1). During the combustion process carbon monoxide is produced, but with adequate oxidant, mixing, and at necessary temperatures much of it is oxidized to carbon dioxide. At the highest IVOP (15 MPa), as timing is advanced CO rapidly increases. This may be explained by the poorer mixing and oxidation conditions that occur at the more advanced timing – the fuel spray is encountering lower pressures and temperatures and because the IVOP is higher, more of the spray encounters these conditions (the increased IVOP results in faster injection: reduced injection period).

The NO_x values between the different IVOPs are not dramatically different (the error bars in Figure 10 (b) between the two IVOPs overlap at low and mid timing). Increasing the IVOP from 9 to 15 MPa does not then drastically increase NO_x. Timing on the other hand does seem to noticeably affect NO_x. The envelope is not as sharp, NO_x somewhat levels off as timing is increased past 25° BTDC. NO_x formation is commonly attributed to the Zeldovich mechanism (a thermal mechanism). With regard to advanced injection timing, Patterson and Henien describe NO formation increasing in two ways [47]. As timing is advanced ignition delay increases but less so than the actual advancement (in terms of crank angle), resulting in earlier autoignition. Higher NO formation is then related to the longer ignition delay as it allows for more fuel evaporation and mixing in the “lean flame region” of the spray. But in other spray regions NO may also increase due to higher temperatures. This description seems applicable to what is observed in Figure 10 (b). Bari et. al. also found NO_x to increase with advanced timing when fueled on WVO [26].

Figure 10 (c) and (d) show the measured UHC and SO₂ concentrations, respectively. Both cases support the same trend observed throughout all of the other IVOP / timing maps. Unburned hydrocarbon emissions appear to stay relatively level at advanced timing likely due to the better

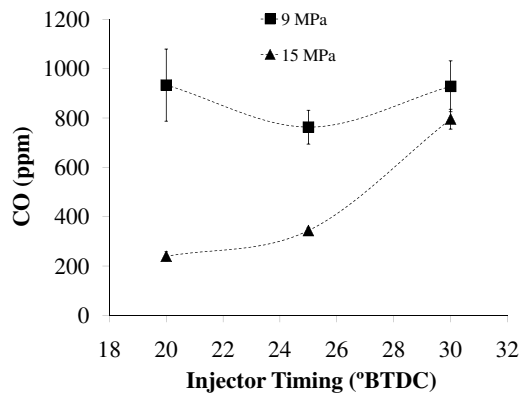

(a)

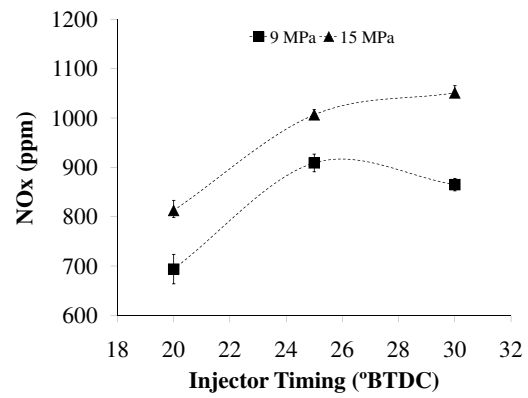

(b)

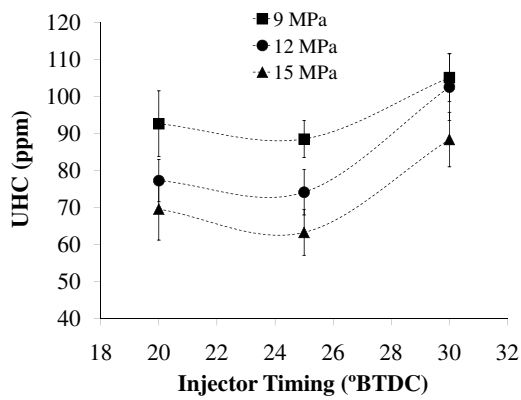

(c)

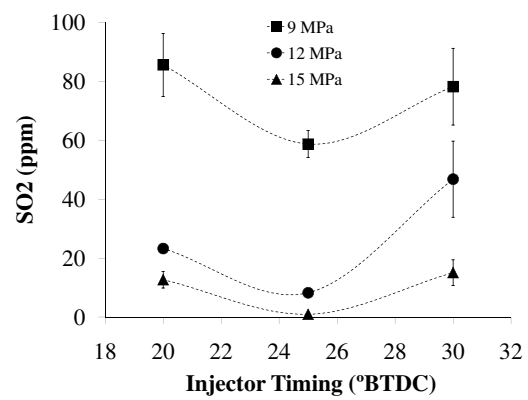

(d)

Figure 10: IVOP & Timing Emissions Map

matching of the ignition delay to timing, but then UHC more rapidly increase as timing is further advanced past 25° BTDC. This may be because as timing continues to be advanced the spray is introduced into lower pressure and temperature conditions which results in less vaporization and larger droplets which may not burn as completely or may potentially impinge on the walls.

In the case of SO₂, emissions became undetectable at the optimized tuning of 25° BTDC with an IVOP of 15 MPa. Sulfur dioxide is produced from the sulfur in the fuel or lubrication oil and is formed more vigorously in fuel-rich conditions (equivalence ratios greater than 1). But even in fuel lean conditions, the air to fuel ratio impacts SO₂ formation. Figure 10 (d) mirrors Figure 8 (d); SO₂ tracks closely with equivalence ratio. The conversion of SO₂ to SO₃ and eventually H₂SO₄ (which is strongly hydrophilic and mixes with water and particulate matter in the exhaust, reducing the amount of SO₂) has been the object of other studies, especially with regard to catalysis design, and it has been shown that the equivalence ratio and exhaust temperature significantly influence these conversions [48]. Given this tendency of SO₂, the lower equivalence ratio and exhaust temperatures are likely the cause of the lower SO₂ emissions at the injection timing of 25° BTDC and IVOP of 15 MPa.

The error bars in Figure 8, Figure 9, and Figure 10 are the standard error across the samples taken per specific IVOP and timing position. Across the figures these error bars tend to decrease as timing is advanced to 25° BTDC and IVOP is increased to 15 MPa. This means that not only does engine performance and emissions tend to improve at this engine tuning position, but the performance and emissions are more consistent.

One limitation of this study's injection tuning exercise is that it was only carried out at one engine loading point, 75% load. Studies such as Bari et. al. have found engine performance and emissions results to vary across loads as timing is changed. This study tuned the timing and IVOP at 75% engine loading as this was assumed to be the most common engine loading for this specific engine in its specific context (agro-processing in developing countries).

5.2. Pre-combustion Pressure

A pressure transducer provided by Kulite Semiconductor Products Inc. was used to map the pressure in the pre-combustion chamber versus the crank angle. Three cases were tested:

- diesel at standard (unmodified) conditions (room temperature fuel, IVOP of 9 MPa, and injector timing of 20° BTDC)
- WVO under unmodified conditions (room temperature fuel, IVOP of 9 MPa, and injector timing of 20° BTDC)
- WVO under modified conditions (fuel heated to 100°C, IVOP of 15 MPa, and injector timing of 25° BTDC).

The engine was loaded to 75% and run at 650 RPM. The pressure transducer was mounted into the COV plug preventing its use as a preheater; instead, the high pressure line was heated electrically.

The pressure traces are shown in Figure 11 (a). Ignition is usually identified by heat release, specifically the initial spike on the rate of heat release (RoHR) curve. To accurately calculate the heat release of an IDI engine both the prechamber and main chamber pressures must be measured. Though heat release can be calculated with only one or the other pressure, the calculation can have as large as a 25% error, especially during early combustion [36]. Due to the availability of only the prechamber pressure, heat release was not calculated. Instead, ignition was approximately

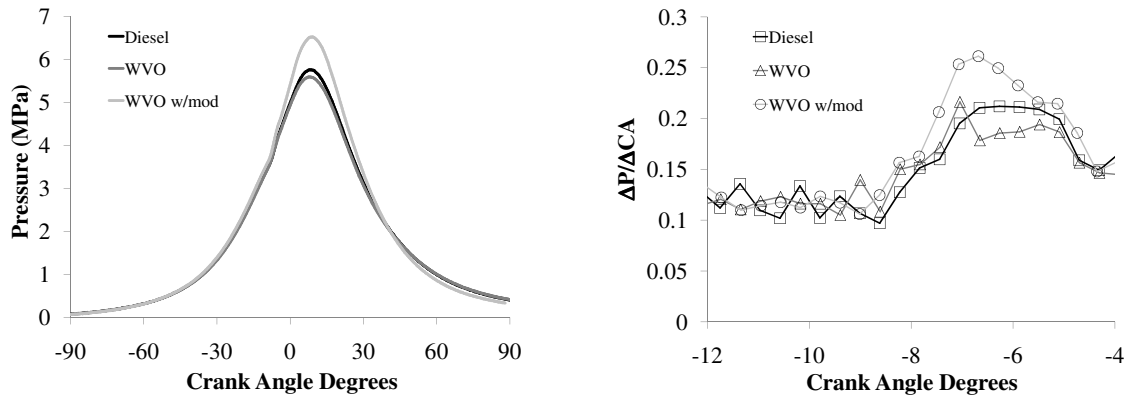

(a) Pre-combustion Chamber Pressure vs. Crank Angle (b) Pre-combustion Chamber Change in Pressure per Change in Crank Angle

Figure 11: Pre-combustion Chamber Pressure

identified by the rapid change in pressure per change in crank angle ($\Delta P/\Delta CA$). From Figure 11 (b) ignition can be identified for each of the three cases. For the purpose of this study the ignition point was specifically defined as the point where the $\Delta P/\Delta CA$ exceeded 0.15 for 2 crank angle degrees.

The summarized ignition points, peak pressure values, and peak pressure points are shown in Figure 12. The ignition point and peak pressure point of diesel and WVO are nearly identical, though the peak pressure value of WVO is lower. The modified WVO case showed a slightly earlier ignition which resulted in an earlier peak pressure point, and higher peak pressure value. Lower viscosity from preheating, advanced injector timing, and increased IVOP are likely all contributing factors to this enhancement to the ignition quality.

5.3. Multi-Load Comparison

From the IVOP-timing maps and pre-combustion traces it was found that an appropriate modification kit would include:

- a COV plug preheater (injector temperature $\sim 90^\circ\text{C}$)
- advanced injection timing (25° BTDC)
- increased IVOP (15 MPa)

This modification kit was then tested across all engine loads, 10%-90%, and compared to diesel and WVO without the modification kit. The diesel and WVO under stock conditions - no injector preheating, injector timing of 20° BTDC, and an IVOP of 9 MPa. Data was taken for each of the three test cases only after bringing the engine to “steady state” conditions at 650 RPM at each of the five loads tested. Data for each case and for each load was then averaged across a one hour “steady state” window. These results are detailed in Figure 13.

The engine performance from the modification kit is favorable. However, this type of a short run test does not illuminate longevity based wear issues that may occur from the WVO without

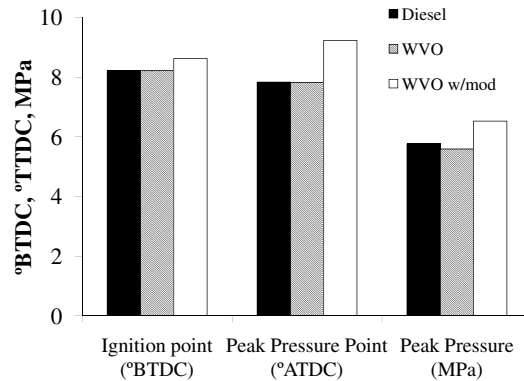

Figure 12: Pre-combustion Pressure Test Summary

modification case. In the short term, the modification kit performed similarly to, though slightly better than the unmodified case, and diesel performed best of all.

Figure 13 (a) shows the measured exhaust temperature. Across all loads: the WVO case was the highest, the WVO case with modification kit was slightly lower, and the diesel case was lower still. As mentioned in the above injection tuning section, the exhaust temperature is likely indicative of the completeness of combustion. The WVO at stock timing, IVOP, and temperature is not combusting as completely as the WVO with the modification kit. Diesel likely had the lowest temperature because it is a lighter fuel than WVO. The heavier (less evaporate) WVO molecules continued to burn late into the cycle, resulting in a higher temperature than the diesel.

Figure 13 (b) shows a similar trend in the System BSFC. The diesel case performed noticeably better than either WVO case. It's important to note that at a calorific value of 45.8 MJ/kg versus WVO's 39.4 MJ/kg, diesel has a strong energy density advantage. The efficiency measurement shown in Figure 13 (c) accounts for this difference in heating values. At higher engine loading the modified WVO case has nearly a 1% gain in efficiency compared to the unmodified WVO case. This same type of trend in BSFC and efficiency was also found by Nwafor et. al. and Bari et al. [42, 26].

The equivalence ratios for each of the three cases in Figure 13 (d) are nearly indistinguishable from one another, though at high loads the unmodified WVO case does have slightly poorer values. Bari et. al. also found the air to fuel ratio to decrease significantly between diesel and WVO, and to decrease slightly more when timing was advanced for the WVO case [26]. The same type of trend was found in this study between the two WVO cases, especially at higher loads. Though the equivalence ratio was not as low.

For each of the three cases the opacity was measured and is detailed in Figure 14. The low levels measured do not present a strong contrast between the three cases, though an interesting phenomenon occurred as engine loading increased: at lower engine loads the diesel exhaust was less opaque but at higher loads the modified WVO performed best. Across all engine loads the unmodified WVO had the most opaque exhaust. This higher opacity level of the WVO without modification seems to follow from its relatively poorer equivalence ratio. The likely explanation of the lower opacity of the exhaust from WVO in the modified engine operation at high load when

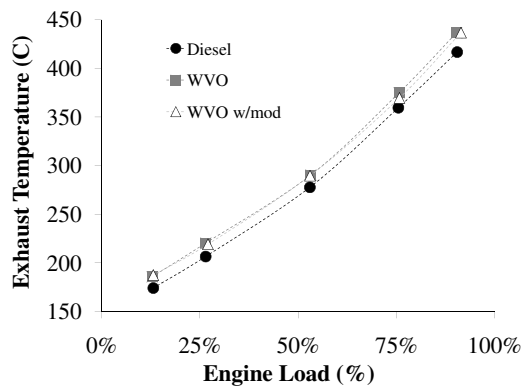

(a)

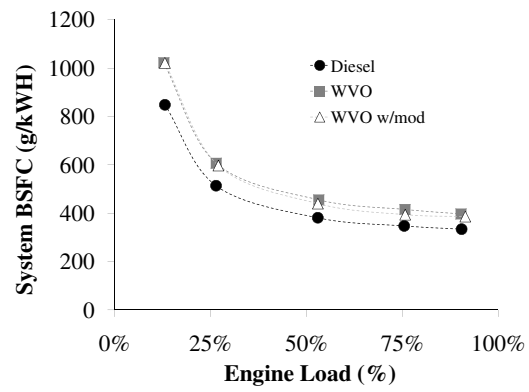

(b)

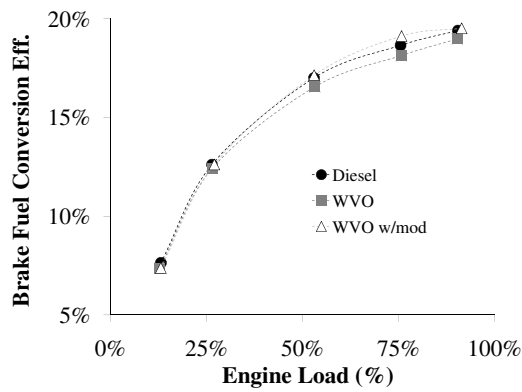

(c)

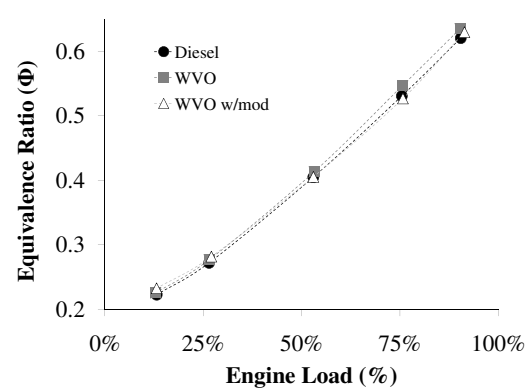

(d)

Figure 13: Multi-load Performance Comparison

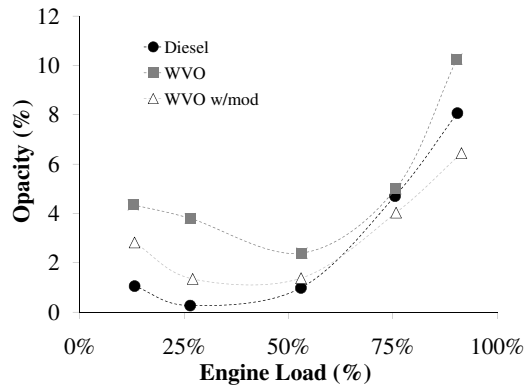

Figure 14: Multi-Load Opacity Comparison

compared to a diesel operated engine is that at low loads the lighter molecular weight of the diesel results in a spray that atomizes to smaller droplet sizes, which burn more completely. But as loading increases, the role of the increased IVOP becomes more important. The likely reduction in droplet size and the improved mixing from the increased IVOP are keeping the equivalence ratio lower than the diesel case and thus the opacity is slightly lower. There is more air to oxidize the fuel, resulting in less soot formation.

The measured emissions for each case are compared in Figure 15. As indicated by the lower CO, UHC, SO₂, and the higher NO_x levels, the diesel seems to have the best combustion characteristics. Unmodified WVO generally emits more CO and SO₂, though the modified WVO case did tend to have slightly higher UHC and lower NO_x.

The CO results for the unmodified WVO and diesel cases shown in Figure 15 (a) resemble the trend found by Bari et. al. [26]. At all loads diesel CO is the lowest. At low loads unmodified WVO is relatively flat, then at mid load the CO begins to increase. The modified WVO case is in between the diesel and unmodified case. This is likely because the modification improves mixing and evaporation, but the heavier WVO molecules with their slower evaporation rate still do not burn as completely as the diesel.

When comparing the opacity values to the CO values of the unmodified WVO case and diesel case at high loads, it appears that the increased availability of oxidant from improved mixing and the lower droplet size (due to the increased IVOP) is enough to reduce the soot, but not enough to also lower the CO below the diesel level. The increased IVOP is definitely impactful, but the WVO is still molecularly heavier than diesel.

The NO_x values in Figure 15 (b) show the diesel to have the highest values across all loads, while both WVO cases are nearly identical. Like the CO, this points to a more complete combustion in the diesel case, which in turn provides hotter temperatures for greater thermal NO_x generation.

The UHC values in Figure 15 (c) also show the diesel to have the best emissions, though at low loads the three cases are very similar. At medium loads the modified WVO case is higher than the unmodified case. This might be due to increased wall impingement from the higher IVOP in the modified case. At high loads the two WVO cases are indistinguishable.

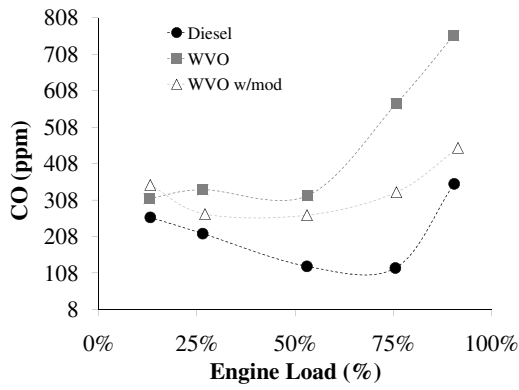

(a)

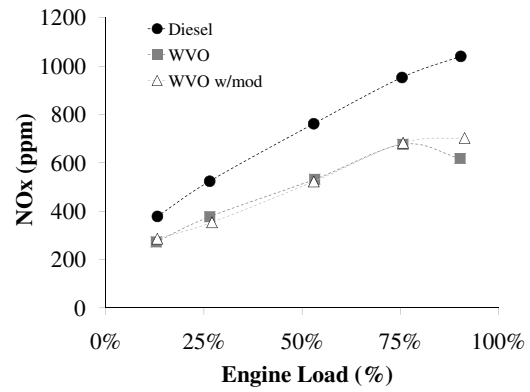

(b)

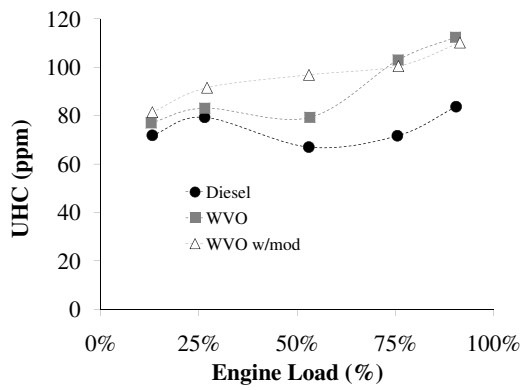

(c)

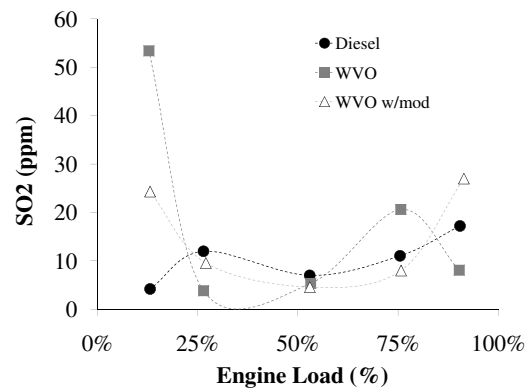

(d)

Figure 15: Multi-load Emissions Comparison

The SO₂ values in Figure 15 (d) are generally noisy, very low, and similar across all cases and all loads. At the lowest loading (10%) the unmodified WVO case is considerably higher than the other two cases. This may be due to the relationship sulfur oxide has with PM as discussed earlier. At this low loading the opacity was low, which may indicate that the sulfur oxides had less soot to attach to, and thus showed up more readily as SO₂. To really understand what is happening to the sulfur a more comprehensive treatment is necessary, especially with regard to the PM. Instead of a simple opacity measurement, gravimetric PM measurements would be valuable, as well as further analysis of the VOF, SO₃, SO₂, etc. Such an exercise is left for future studies.

6. Conclusions

Plant oils have potential as a fuel source for stationary engines used for agricultural processing in remote developing community contexts. The role that different SVO physical and chemical properties have on combustion has been discussed. Similarly, engine design differences and modifications applicable to SVO fueling have been described.

An experimental investigation was carried out involving the design of a unique preheating modification for an IDI engine common in developing countries, raising the temperature at the injector to 90 degrees Celsius. The engine was also tuned to an increased IVOP and advanced timing appropriate to the combustion characteristics of preheated SVOs. It was found that 25° BTDC with an IVOP of 15 MPa was ideal for the specific engine when fueled on waste vegetable oil. Experiments were carried out that showed improved performance and emission characteristics from the utilization of this three part modification kit. These improvements included lower exhaust temperatures, lower brake specific fuel consumption, lower equivalence ratio, increased thermal efficiency, lower opacity, and lower carbon monoxide.

7. Acknowledgments

This project was supported by the Gates Foundation, Darren Manelski, and the Three Loaves Fund. This support is gratefully acknowledged. The authors would like to thank Kulite Semiconductor Products Inc. for the use of their pressure transducer, and Adam Hurst for his assistance. The assistance received from Marco Castaldi, Alissa Park, and Will Northrop is also gratefully acknowledged. Additionally the support, guidance, and expert advice provided by George Breckenridge is recognized, without which this research would not have been possible.

Appendix A. Selected Properties of Several Plant Oils and Diesel

Table A.2: Physical and Fuel Properties of Several Plant Oils and Diesel

	Diesel	Soybean	Rapeseed	Peanut	Palm	Jatropha	WVO
Yield (L/Ha-Yr)	–	450-480	590-1200	850-1100	2800-6000	740-1590	–
Viscosity (cSt) ^a	2.6-3.6	33	37-42	40	39	34-37	36
Density (kg/m ³)	820-845	914-924	912-920	888-902	860-910	860-933	910-940
Calorific Value (MJ/kg)	43-46	36.9-39.6	36.8-39.7	39.5-39.8	36.5-40.1	37.8-42.1	39.2-39.6
Cetane Number	45-56	36-38	38-41	35-42	42-49	38-45	36-37
Reference	[49, 50, 51, 52, 53]	[49, 11, 54, 55, 56, 57, 53, 58]	[11, 54, 55, 58, 5, 56, 57, 53]	[11, 54, 55, 58, 59, 56, 57, 53]	[11, 30, 50, 55, 52, 56, 57]	[60, 61, 11, 12, 55, 56, 62, 57]	original data

^aViscosity of Diesel, Palm, Jatropha, and WVO measured at 40C; all others measured at 38C

Table A.3: Chemical Composition of Several Plant Oils and Diesel

Element	Diesel	Soybean	Rapeseed	Peanut	Palm	Jatropha	WVO
C	80.33-86	76.2-77.1	77.9-78	70-76.55	50.27	76.11-76.56	76.50-77.78
H	12.36-14.8	11.6-12.9	10-13.2	11.97	7.07	10.52-13.19	11.55-12.07
O	1.19	10-10.4	8.9-12	11.48	36.28	11.06	11.1-11.57
S	0.1-0.25	0.01	0.0012-0.01	0.01	0.4-0.63	–	0.02-0.03
N	1.76	1.9	–	–	0.42	0.34	0.02-0.03
C Residue	0.1-0.14	0.24-0.27	0.3-0.31	0.22-0.24	0.22-0.24	0.7-0.9	–
Ash	0.01	0.006-0.01	0.01-0.54	0.005-0.02	5.33	0.03-0.036	–
Reference	[61, 5, 52, 53]	[54, 58, 63, 53]	[54, 58, 64, 5]	[54, 58, 64]	[52, 65]	[60, 61, 12]	original data

Table A.4: Lipid Profile of Several Plant Oils

Lipids	Plant Oil:					
	Soybean	Rapeseed	Peanut	Palm	Jatropha	WVO
Lauric (C12:0)	–	–	–	0-1.15	5.9	0.02-0.04
Myristic (C14:0)	–	–	0.1	0.5-2.74	0.1-2.7	0.14-0.25
Palmitic (C16:0)	11.3-13.9	3.49-3.5	8-11.34	26.18-47.5	14.1-15.3	6.74-12.4
Palmitoleic (C16:1)	0.1-0.3	–	–	0.1-1.66	1.3	0.47-1.0
Stearic (C18:0)	2.1-3.6	0.85-1.6	1.8-2.4	3.5-11.97	3.7-9.8	2.79-4.47
Oleic (C18:1)	23.2-24.9	33-64.4	48.28-53.3	35.49-46.1	21.8-45.8	31.50-58.2
Linoleic (C18:2)	53-56.2	20.4-22.3	28.4-32	6.5-12.76	29-47.4	21.2-42.20
Linolenic (C18:3)	4.3-6.31	7.9-8.23	0.3-0.93	0-2.25	0.3	5.85-7.4
Arachidic (C20:0)	0.3	–	0.9-1.32	0.4-1.74	0.3	0.39-0.62
Gadoleic (C20:1)	0.3	9.3	2.4	0.2-2.56	–	–
Behenic (C22:0)	–	–	2.52-3	–	0.2	0.34-0.35
Erucic (C22:1)	0.3	23	–	0-1.49	–	0.06-0.08
Lignoceric (C24:0)	0.1	–	1.23-1.8	0.1	–	0.07-0.09
Iodine Value	69.82-152	81-120	80-119.55	44-65.5	92-112	107-115
Reference	[54, 58, 18, 9, 66]	[54, 58, 18, 9, 66]	[67, 54, 58, 18, 66]	[67, 18, 9, 66]	[60, 68, 69]	original data

References

- [1] P. Vasudevan, S. Sharma, A. Kumar, Liquid fuel from biomass: an overview, *Journal of Scientific & Industrial Research* 64 (11) (2005) 822–831.
- [2] United States Department of Energy, *Annual energy report* (2008).
- [3] D. Pimentel, A. Marklein, M. A. Toth, M. N. Karpoff, G. S. Paul, R. McCormack, J. Kyriazis,

- T. Krueger, Food versus biofuels: Environmental and economic costs, *Human Ecology* 37 (1) (2009) 1–12.
- [4] V. Modi, Energy services for the poor, Tech. rep., Millennium Project Task Force 1 (2004).
- [5] N. Hemmerlein, V. Korte, H. Richter, G. Schroder, Performance, exhaust emissions and durability of modern diesel engines running on rapeseed oil, SAE Paper 910848 (1991).
- [6] T. W. Ryan, L. G. Dodge, T. J. Callahan, The effects of vegetable oil properties on injection and combustion in two different diesel engines, *Journal of the American Oil Chemists* 61 (10) (1984) 1610–1619.
- [7] Y. Hui (Ed.), *Bailey’s Industrial Oil & Fat Products*, 5th Edition, Wiley, New York, 1996.
- [8] M. S. Graboski, R. L. McCormick, Combustion of fat and vegetable oil derived fuels in diesel engines, *Progress in Energy and Combustion Science* 24 (2) (1998) 125–164.
- [9] S. L. Nettles-Anders, D. B. Olsen, Survey of straight vegetable oil composition impact on combustion properties, SAE Paper 2009-01-0487 (2009).
- [10] A. S. Ramadhas, S. Jayaraj, C. Muraleedharan, Use of vegetable oils as i.c. engine fuels—a review, *Renewable Energy* 29 (5) (2004) 727–742.
- [11] A. Babu, G. Devaradjane, Vegetable oils and their derivatives as fuels for ci engines: An overview, SAE Paper 2003-01-0767 (2003).
- [12] H. K. Gangwar, A. K. Agarwal, Emission and combustion characteristics of vegetable oil (*jatropha curcus*) blends in an indirect ignition transportation engine, SAE Paper 2008-28-0034 (2008).
- [13] C. Rakopoulos, K. Antonopoulos, D. Rakopoulos, D. Hountalas, E. Giakoumis, Comparative performance and emissions study of a direct injection diesel engine using blends of diesel fuel with vegetable oils or bio-diesels of various origins, *Energy Conversion and Management* 47 (18–19) (2006) 3272–3287.
- [14] L. Schumacher, Biodiesel lubricity, Tech. rep., University of Idaho (2003).
- [15] R. Korus, J. Jo, C. Peterson, A rapid engine test to measure injector fouling in diesel engines using vegetable oil fuels, *Journal of the American Oil Chemists’ Society* 62 (11) (1985) 1563–1564.
- [16] A. Schonborn, N. Ladommatos, R. Allan, J. Williams, J. Rogerson, Effect of the molecular structure of individual fatty acid alcohol esters (biodiesel) on the formation of nox and particulate matter in the diesel combustion process, SAE Paper 2008-01-1578 (2008).
- [17] T. W. I. Ryan, M. O. Bagby, Identification of chemical changes occurring during the transient injection of selected vegetable oils, SAE Paper 930933 (1993).
- [18] G. Knothe, Structure indices in fa chemistry. how relevant is the iodine value?, *Journal of the American Oil Chemists’ Society* 79 (9) (2002) 847–854.

- [19] P. Mondal, M. Basu, N. Balasubramanian, Direct use of vegetable oil and animal fat as alternative fuel in internal combustion engine, *Biofuels Bioproducts & Biorefining-Biofpr* 2 (2) (2008) 155–174.
- [20] C. Peterson, S. Jones, Using unmodified vegetable oils as a diesel fuel extender a literature review, Tech. rep., University of Idaho (2002).
- [21] P. A. D. A. K. Hossain, Plant oils as fuels for compression ignition engines: A technical review and life-cycle analysis, *Renewable Energy* 35 (2010) 1–13.
- [22] M. Vojtisek-Lom, J. Blazek, M. Dufek, M. Fenkl, Investigation of combustion rates and injection and ignition onset of heated rapeseed oil in direct-injection turbodiesel engines, Tech. Rep. 2009-01-1914, SAE (2009 2009).
- [23] C. Engler, L. Johnson, W. Lepori, C. Yarbrough, Effects of processing and chemical characteristics of plant oils on performance of an indirect-injection diesel engine 60 (8) (1983) 1592–1596.
- [24] K. J. Suda, Vegetable oil or diesel fuel-a flexible option, Tech. Rep. 840004, SAE International, engine Study (1984 1984).
- [25] S. Bari, C. Yu, T. Lim, Filter clogging and power loss issues while running a diesel engine with waste cooking oil, *Proceedings of the Institution of Mechanical Engineers. Part D, Journal of automobile engineering* 216 (12) (2002) 993–1001.
- [26] S. Bari, C. W. Yu, T. H. Lim, Effect of fuel injection timing with waste cooking oil as a fuel in a direct injection diesel engine, *Proceedings of the Institution of Mechanical Engineers Part D-Journal of Automobile Engineering* 218 (D1) (2004) 93–104.
- [27] M. Pugazhivadivu, K. Jeyachandran, Investigations on the performance and exhaust emissions of a diesel engine using preheated waste frying oil as fuel, *Renewable Energy* 30 (14) (2005) 2189–2202.
- [28] O. M. I. Nwafor, The effect of elevated fuel inlet temperature on performance of diesel engine running on neat vegetable oil at constant speed conditions, *Renewable Energy* 28 (2) (2003) 171–181.
- [29] J. Dweck, C. Sampaio, Analysis of the thermal decomposition of commercial vegetable oils in air by simultaneous tg/dta, *Journal of Thermal Analysis and Calorimetry* 75 (2) (2004) 385–391.
- [30] S. Bari, T. H. Lim, C. W. Yu, Effects of preheating of crude palm oil (cpo) on injection system, performance and emission of a diesel engine, *Renewable Energy* 27 (3) (2002) 339–351.
- [31] I. Celikten, An experimental investigation of the effect of the injection pressure on engine performance and exhaust emission in indirect injection diesel engines, *Applied Thermal Engineering* 23 (16) (2003) 2051–2060.
- [32] Z.-M. Cao, K. Nishino, S. Mizuno, K. Torii, Piv measurement of internal structure of diesel fuel spray, *Experiments in fluids* 29 (7) (2000) S211–S219.

- [33] K. Enoki, S. Hayashi, N. Sawa, Effective utilization of blended plant fuels for pre-combustion chamber compression ignition engines, SAE Paper 940330 (1994).
- [34] T. Su, C. Chang, R. Reitz, P. Farrell, A. Pierpont, T. Tow, Effects of injection pressure and nozzle geometry on spray smd and d.i. emissions, SAE Paper 952360 (1995).
- [35] K. Varde, D. Popa, L. Varde, A study of diesel spray characteristics at high injection, Tech. rep., U.S. Dept. of Transportation, Office of the Secretary of Transportation (1985).
- [36] J. B. Heywood, Internal Combustion Engine Fundamentals, McGraw-Hill Book Company, New York, 1988.
- [37] K. Openshaw, A review of jatropha curcas: an oil plant of unfulfilled promise, Biomass and Bioenergy 19 (1) (2000) 1–15.
- [38] C. S. Lee, S. W. Park, S. I. Kwon, An experimental study on the atomization and combustion characteristics of biodiesel-blended fuels, Energy & Fuels 19 (5) (2005) 2201–2208.
- [39] T. Murayama, Y.-t. Oh, N. Miyamoto, T. Chikahisa, N. Takagi, K. Itow, Low carbon flower buildup, low smoke, and efficient diesel operation with vegetable oils by conversion to monoesters and blending with diesel oil or alcohols, SAE Paper 841161 (1984).
- [40] S. Puhan, R. Jegan, K. Balasubramanian, G. Nagarajan, Effect of injection pressure on performance, emission and combustion characteristics of high linolenic linseed oil methyl ester in a di diesel engine, Renewable Energy 34 (5) (2009) 1227–1233.
- [41] S. Haldar, B. Ghosh, A. Nag, Studies on the comparison of performance and emission characteristics of a diesel engine using three degummed non-edible vegetable oils, Biomass and Bioenergy 33 (8) (2009) 1013–1018.
- [42] O. M. I. Nwafor, G. Rice, A. I. Ogbonna, Effect of advanced injection timing on the performance of rapeseed oil in diesel engines, Renewable Energy 21 (3-4) (2000) 433–444.
- [43] SAE International, Measurement of intake air or exhaust gas flow of diesel engines, SAE International Standard J244 (1992).
- [44] R.A. Lister & Co., Ltd., Dursley, Gloucestershire, England, Instruction Book and Spare Parts List.
- [45] B. Gebhart, Y. Jaluria, R. J. Mahajan, B. Sammakia (Eds.), Buoyancy-Induced Flows and Transport, Hemisphere Publishing Company, New York, 1988.
- [46] W. M. Rohsenow, J. P. Hartnett, E. N. Ganic (Eds.), Handbook of Heat Transfer Fundamentals, McGraw-Hill Book Company, New York, 1985.
- [47] D. J. Patterson, N. A. Henein, Emissions from Combustion Engines and Their Control, Ann Arbor Science Publishers Inc., Ann Arbor, 1972.
- [48] G. Corro, Sulfur impact on diesel emission control - a review, Reaction Kinetics and Catalysis Letters 75 (1) (2002) 89–106.

- [49] E. Alptekin, M. Canakci, Characterization of the key fuel properties of methyl ester-diesel fuel blends, *Fuel* 88 (1) (2009) 75–80.
- [50] S. C. A. de Almeida, C. R. Belchior, M. V. G. Nascimento, L. d. S. R. Vieira, G. Fleury, Performance of a diesel generator fuelled with palm oil, *Fuel* 81 (16) (2002) 2097–2102.
- [51] M. D. Clevenger, M. O. Bagby, C. E. Goering, A. W. Schwab, L. D. Savage, Developing an accelerated test of coking tendencies of alternative fuels, *Transactions of the ASAE* 31 (4) (1988) 1054–1058.
- [52] M. A. Kalam, H. H. Masjuki, Emissions and deposit characteristics of a small diesel engine when operated on preheated crude palm oil, *Biomass and Bioenergy* 27 (3) (2004) 289–297.
- [53] H. Masjuki, A rapid test to measure performance, emission and wear of a diesel engine fueled with palm oil diesel, *Journal of the American Oil Chemists' Society* 70 (1993) 1021–1025.
- [54] A. Demirbas, Chemical and fuel properties of seventeen vegetable oils, *Energy Sources* 25 (7) (2003) 721–728.
- [55] P. Girard, A. Fallot, Review of existing and emerging technologies for the production of biofuels in developing countries, *Energy for Sustainable Development* 10 (2) (2006) 92–108, development.
- [56] W. Korbitz, Worldwide trends in production and marketing of biodiesel, *Austrian Biofuels Institute* (May 2000).
- [57] V. Modi, S. McDade, D. Lallement, J. Saghir, Energy services for the millenium development goals, *Tech. rep.*, UNDP (2005).
- [58] C. Goering, A. Schwab, M. Daugherty, E. Pryde, A. Keakin, Fuel properties of eleven vegetable oils, *American Society of Agricultural Engineers CONF-811221* (1982).
- [59] R. Altin, S. Cetinkaya, H. S. Yucesu, The potential of using vegetable oil fuels as fuel for diesel engines, *Energy Conversion and Management* 42 (5) (2001) 529–538.
- [60] W. Achten, L. Verchot, Y. Franken, E. Mathijs, V. Singh, R. Aerts, B. Muys, *Jatropha* biodiesel production and use, *Biomass and Bioenergy* 32 (12) (2008) 1063–1084, *jatropha*.
- [61] D. Agarwal, A. K. Agarwal, Performance and emissions characteristics of *jatropha* oil (pre-heated and blends) in a direct injection compression ignition engine, *Applied Thermal Engineering* 27 (13) (2007) 2314–2323.
- [62] E. L. M. Rabe, *Jatropha* oil in compression ignition engines, Ph.D. thesis, Eindhoven University of Technology (2007).
- [63] T.-A. Ngo, J. Kim, S. K. Kim, S.-S. Kim, Pyrolysis of soybean oil with h-zsm5 (proton-exchange of zeolite socony mobil??5) and mcm41 (mobil composition of matter no. 41) catalysts in a fixed-bed reactor, *Energy* In Press, Corrected Proof.
- [64] C. Kaya, C. Hamamci, A. Baysal, O. Akba, S. Erdogan, A. Saydut, Methyl ester of peanut (*arachis hypogea* l.) seed oil as a potential feedstock for biodiesel production, *Renewable Energy* 34 (5) (2009) 1257–1260.

- [65] M. O. Bagby, Vegetable oils for diesel fuel: Opportunities for development, Tech. Rep. 87-1588, American Society of Agricultural Engineers (1987).
- [66] T. Ogawa, M. Okada, Influence of properties and composition of diesel fuels on particle emissions, Tech. rep., R&D Review of Toyota CRDL (November 2003).
- [67] A. Abollé, L. Kouakou, H. Planche, The viscosity of diesel oil and mixtures with straight vegetable oils: Palm, cabbage palm, cotton, groundnut, copra and sunflower, Biomass and Bioenergy In Press, Corrected Proof.
- [68] J. S. de Oliveira, P. M. Leite, L. B. de Souza, V. M. Mello, E. C. Silva, J. C. Rubim, S. M. Meneghetti, P. A. Suarez, Characteristics and composition of jatropha gossypifolia and jatropha curcas l. oils and application for biodiesel production, Biomass and Bioenergy 33 (3) (2009) 449–453.
- [69] M. Senthil Kumar, A. Ramesh, B. Nagalingam, An experimental comparison of methods to use methanol and jatropha oil in a compression ignition engine, Biomass and Bioenergy 25 (3) (2003) 309–318.